

Pos. B406 Allgemeines Stützensystem
System

A	vK	bK	von [m]	bis [m]	h [m]	Versatz [cm]	y/z [cm]	Q
1	1	2	6.70	3.50	3.20	0.0	0.0	1
2	2	3	3.50	0.00	3.50	0.0	2.2	2

Randbedingungen

RB	K	Verschiebung [kN/m]	verdrehung [kNm/rad]
		Cty	Crz
1	1	starr	frei
	2	starr	frei
	3	starr	frei

Querschnitte

Q	Typ	Bew.Art	b/D [cm]	d/Di [cm]	b1 [cm]	d1 [cm]
1	Allgem.	Form				
2	Allgem.	Form				

Eckpunkte

Q	Ecke	y [cm]	z [cm]	Ecke	y [cm]	z [cm]
1	1	25.00	0.00	2	40.00	10.00
	3	40.00	20.00	4	50.00	20.00
	5	50.00	35.00	6	0.00	35.00
	7	0.00	20.00	8	10.00	20.00
	9	10.00	10.00			
2	1	25.00	10.00	2	40.00	10.00
	3	40.00	20.00	4	50.00	20.00
	5	50.00	35.00	6	0.00	35.00
	7	0.00	20.00	8	10.00	20.00
	9	10.00	10.00			

Materialien

Q	B	BSt	my- [%]	my+ [%]	mydin [%]	phi [-]	A [cm ²]	gamma [kN/m ³]
1	25	500	0.40	9.00	0.80	2.50	1200	25.00
2	25	500	0.40	9.00	0.80	2.50	1050	25.00

M 1:10

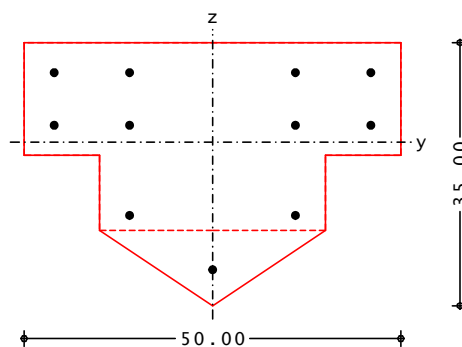

Abschnitt 1

M 1:10

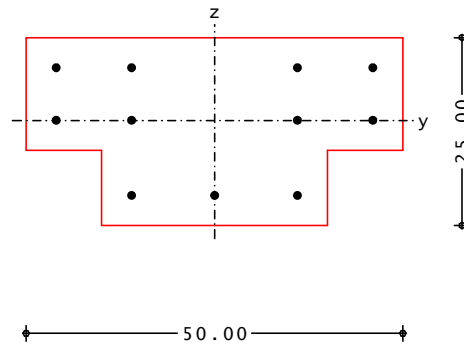

Abschnitt 2

Belastung

Knotenlasten und Abschnittslasten für LF 0 bis 2

LF 0	K 1	vertik. ey/z = 0.0/-10.0 cm	V = 100.0	kN
	K 2	Vertikallast	V = 210.0	kN
LF 1	K 1	vertik. ey/z = 0.0/-10.0 cm	V = 100.0	kN
	K 2	Vertikallast	V = 210.0	kN
LF 2	A 1-	1 Gleichl. Z	qz = 4.00	kN/m
	A 2-	2 Gleichl. Z	qz = 2.50	kN/m
	K 1	vertik. ey/z = 0.0/-10.0 cm	V = 100.0	kN
	K 2	vertik. ey/z = 0.0/-10.0 cm	V = 65.0	kN
	K 2	Vertikallast	V = 210.0	kN
	K 2	Vertikallast	V = 145.0	kN
	A 1-	1 Gleichl. Z	qz = 4.00	kN/m
	A 2-	2 Gleichl. Z	qz = 2.50	kN/m

Die Eigenlast der Stütze wird berücksichtigt.

 Lastfall 0
M 1:95

System in y-Richtung

in z-Richtung

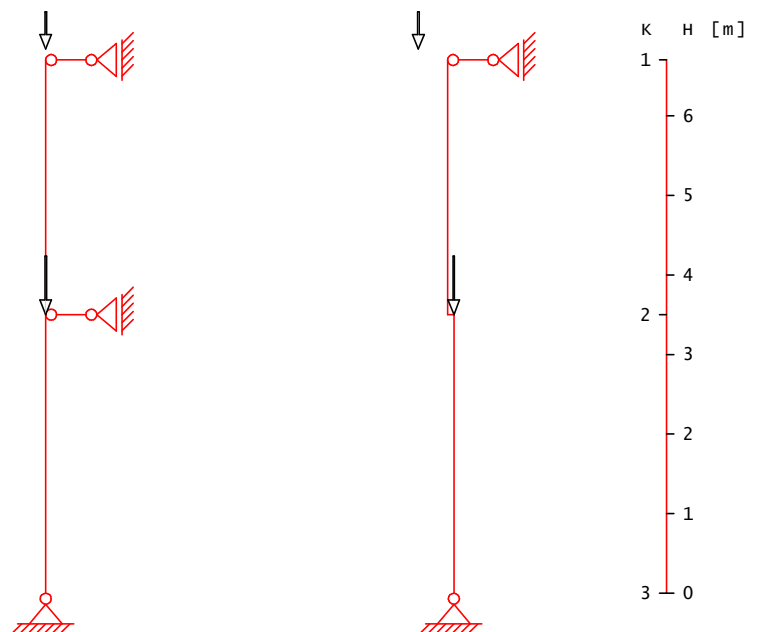

Lastfall 1
M 1:95

System in y-Richtung

in z-Richtung

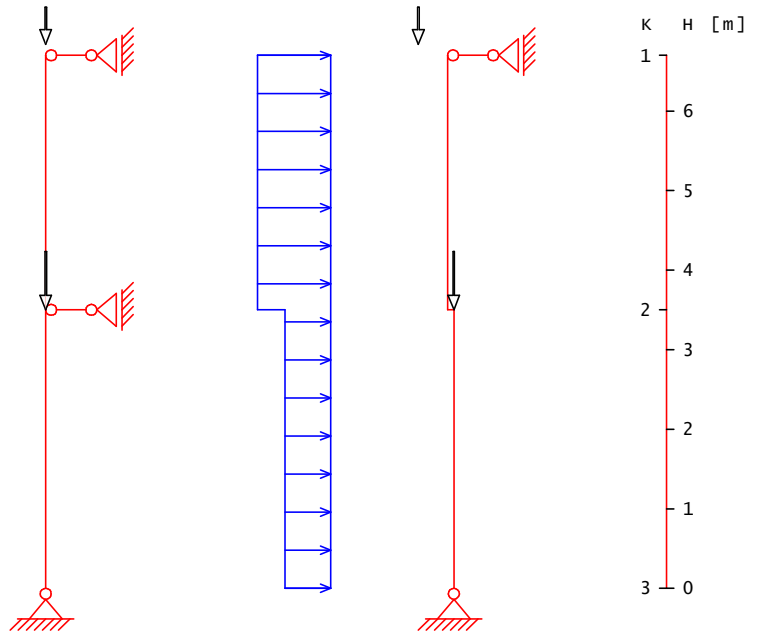

Lastfall 2
M 1:95

System in y-Richtung

in z-Richtung

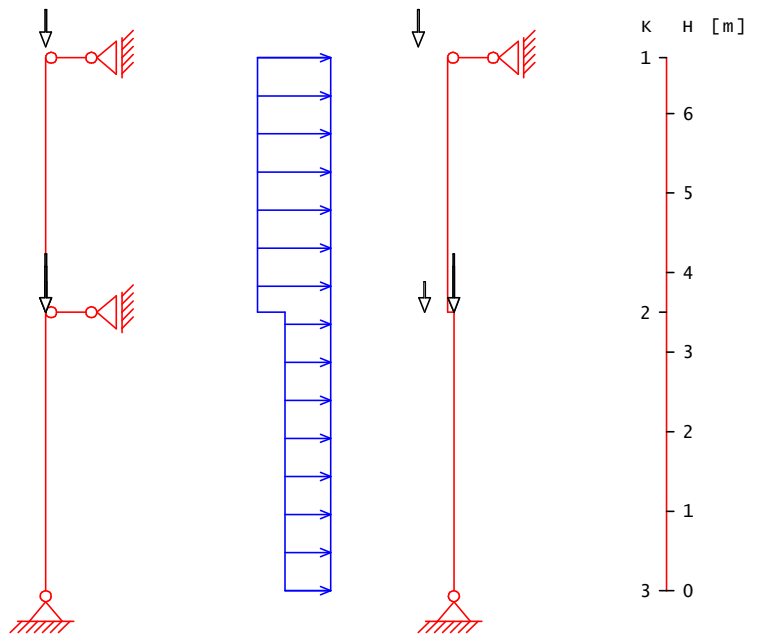

Bemessung

Lastfall 0 Berechnung für Dauerlast nach linear-elastischer Th.II.0. mit einem wirksamen Elastizitätsmodul $E_b / (1 + \phi)$

Randbedingung 1 Knicken in y/z-Richtung möglich
 Knicklastfaktoren $n_y / n_z = 90.57 / 7.74 -$

LF 0

Biegesteifigkeiten

Q	my [%]	(EI _y) _b [MNm ²]	(EI _z) _b [MNm ²]	EI _y [MNm ²]	EI _z [MNm ²]
1	0.95	7.7	15.8	9.5	21.2
2	2.77	4.3	15.3	7.0	29.1

Ungew. Ausmitte affin zur Knickfigur aufgebracht.
 Knicklängenfaktoren $\beta_y / \beta_z = 0.46 / 0.91 -$

LF 0

Ungewollte Ausmitte

H [m]	ey [cm]	H [m]	ez [cm]
1.68	1.04	3.01	2.03

LF 0

Verformungen

K	wy [cm]	wz [cm]	dy [rad]	dz [rad]
1	0.00	0.00	-0.01199	0.00485
2	0.00	2.66	-0.00283	-0.00746
3	0.00	0.00	0.01412	0.00994

Verformungen
 M 1:90

in y-Richtung

in z-Richtung

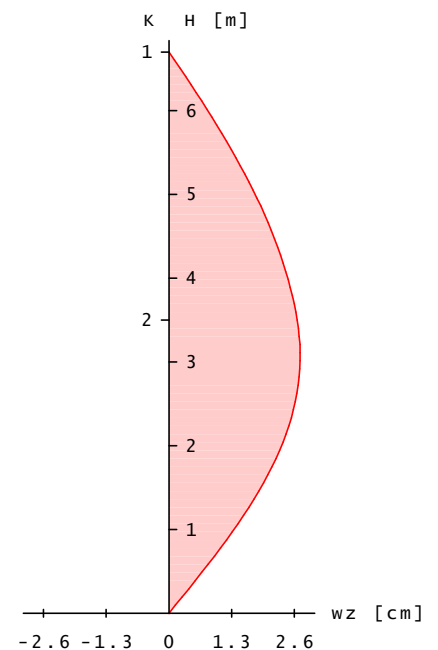
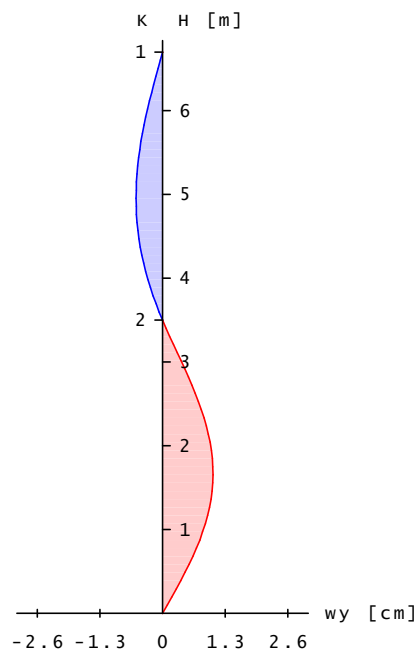

Lastfall 1

Randbedingung 1 Knicken in y/z-Richtung möglich
 Knicklastfaktoren $n_y / n_z = 181.19 / 17.51 -$
 Schlankheiten $\lambda_{b,y} / \lambda_{b,z} = 24.42 / 78.56 -$

Ausmitte inf.Kriechen wird vom Programm ermittelt.

Ungew. Ausmitte affin zur Knickfigur aufgebracht.
 Knicklängenfaktoren $\beta_y / \beta_z = 0.45 / 1.02$ -

LF 1

Ungewollte Ausmitte

Ky	H	ey	Kz	H	ez
	[m]	[cm]		[m]	[cm]
--	1.63	1.01	--	2.91	2.27

Lastfall 1 Regelbemessung nach linearer Th.I.O. mit 1.00-facher Last

LF 1 Th.I.O.
Schnittgrößen

K	N	My	Mz	Qy	Qz
	[kN]	[kNm]	[kNm]	[kN]	[kN]
1	100.00	-10.00	0.00	0.00	-10.18
2	109.60	-22.11	0.00	0.00	2.62
3	319.60	-24.47	0.00	0.00	2.62
	328.79	0.00	0.00	0.00	11.37

Biegemoment
M 1:90

um y-Achse

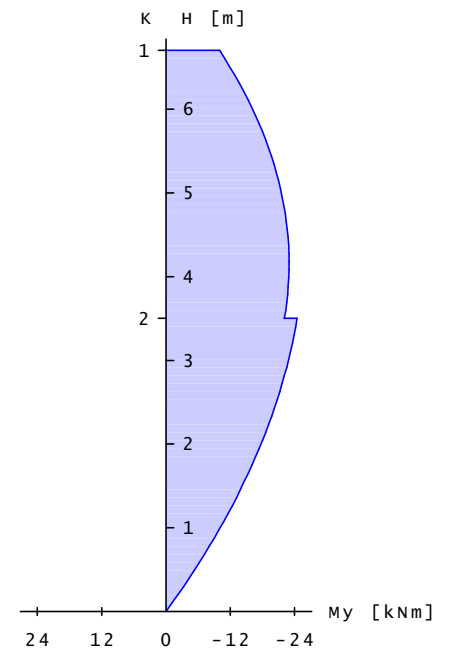

LF 1 Th.I.O.
Verformungen

K	wy	wz	dy	dz
	[cm]	[cm]	[rad]	[rad]
1	0.00	0.00	-0.00285	0.00000
2	0.00	0.58	-0.00054	0.00000
3	0.00	0.00	0.00291	0.00000

Verformung
M 1:90

in z-Richtung

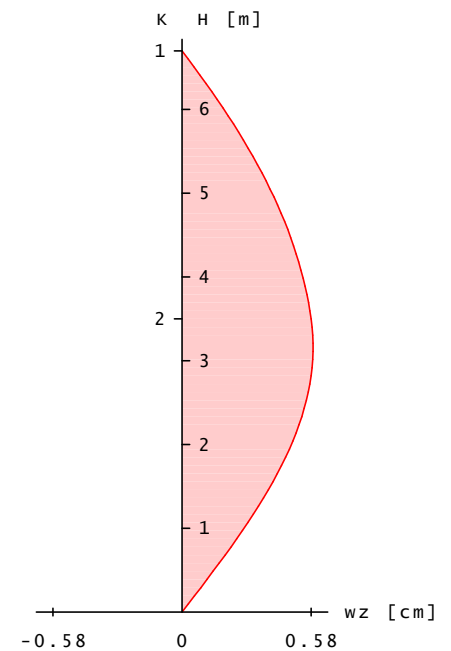

LF 1 Th.I.O.
Bruchschnittgrößen

K	Nu [kN]	Myu [kNm]	Mzu [kNm]	EpsS [%.]	EpsB [%.]	my [%.]
1	822.80	-82.28	0.00	0.99	-3.50	0.40
2	359.68	-72.55	0.00	2.89	-3.50	0.40
	825.25	-63.19	0.00	1.14	-3.50	0.57
3	2090.29	0.00	0.00	-2.00	-2.00	0.57

Lastfall 1 Knicksicherheitsnachweis n. Th.II.O. mit 1.75-facher Last

LF 1 KSNW
Schnittgrößen

K	N [kN]	My [kNm]	Mz [kNm]	Qy [kN]	Qz [kN]
1	175.00	-17.50	0.00	1.08	-34.32
2	191.80	-83.34	1.13	-0.91	-4.57
	559.30	-87.48	1.13	-4.09	-8.61
3	575.38	0.00	0.00	5.51	46.42

Biegemomente
M 1:90

um z-Achse

um y-Achse

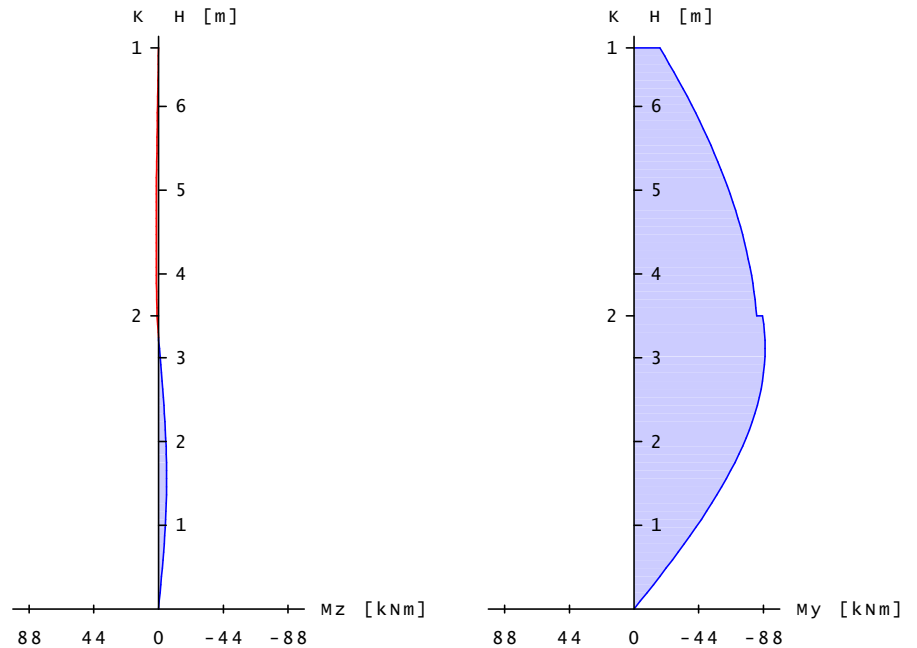

LF 1 KSNW
Verformungen

K	wy u [cm]	wz u [cm]	wy k [cm]	wz k [cm]	wy [cm]	wz [cm]
1	0.00	0.00	0.00	0.00	0.00	0.00
2	0.00	2.16	0.00	0.46	0.00	12.23
3	0.00	0.00	0.00	0.00	0.00	0.00

Vorverformungen
M 1:90

in y-Richtung

in z-Richtung

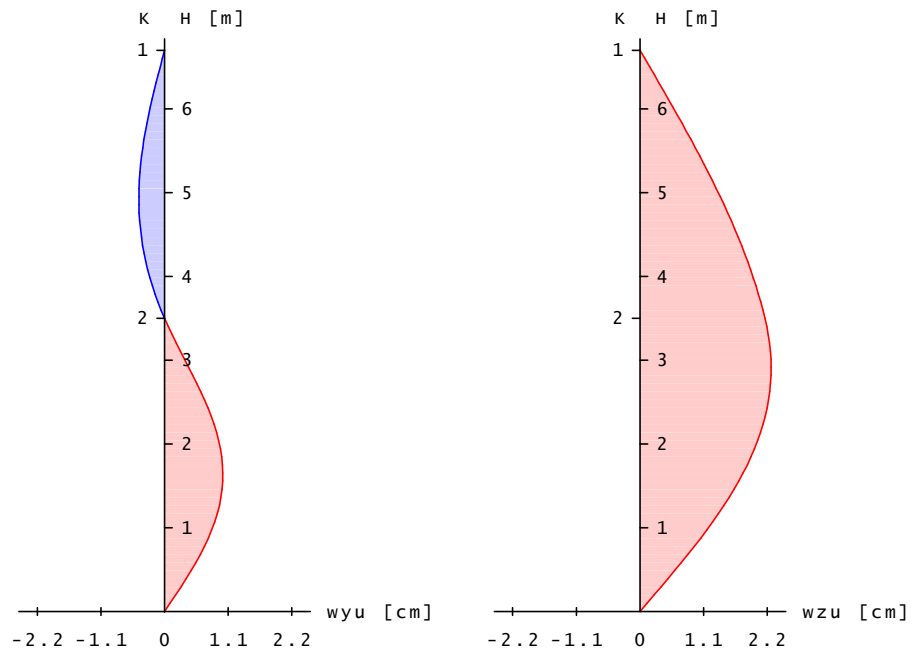

LF 1 KSNW
 Bruchschnittgrößen

K	Nu [kN]	Myu [kNm]	Mzu [kNm]	EpsS [%.]	EpsB [%.]	my [%.]
1	914.87	-91.49	0.00	0.83	-3.50	0.79
2	191.80	-83.34	1.13	3.35	-3.50	0.79
3	568.75	-88.96	1.15	2.00	-3.50	1.58
	2532.38	0.00	0.00	-1.99	-2.01	1.58

 LF 1 KSNW
 Auflagergr. / 1.75

K	Hy [kN]	HZ [kN]	A [kN]	My [kNm]	Mz [kNm]
1	-0.21	14.20	0.00	0.00	0.00
2	0.41	0.00	0.00	0.00	0.00
3	-0.20	7.35	328.79	0.00	0.00

Lastfall 1 Schnittgrößenermittlung n. Th.II.O. für Gebrauchszustand

 LF 1 GZ
 Verformungen

K	wy u [cm]	wz u [cm]	wy k [cm]	wz k [cm]	wy [cm]	wz [cm]
1	0.00	0.00	0.00	0.00	0.00	0.00
2	0.00	2.16	0.00	0.46	0.00	5.22
3	0.00	0.00	0.00	0.00	0.00	0.00

 Verformungen
 M 1:90

in y-Richtung

in z-Richtung

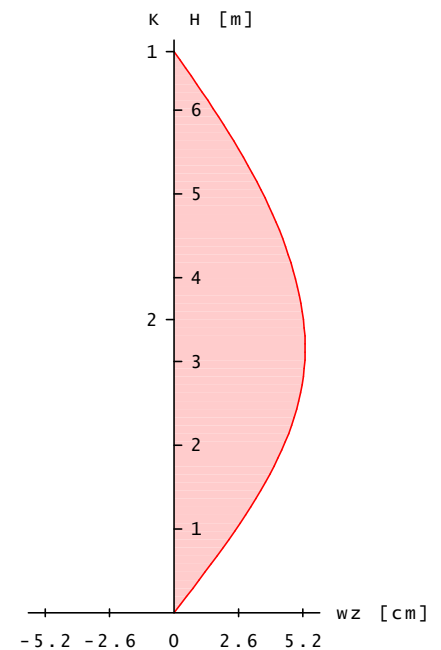
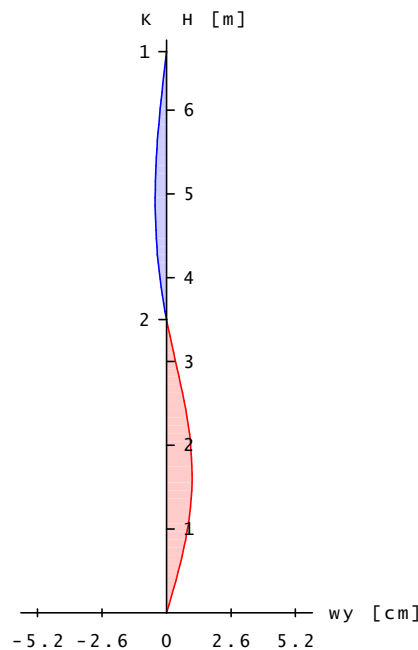
 LF 1 GZ
 Auflagergrößen

K	Hy [kN]	HZ [kN]	A [kN]	My [kNm]	Mz [kNm]
1	-0.15	11.92	0.00	0.00	0.00
2	0.30	0.00	0.00	0.00	0.00
3	-0.15	9.63	328.79	0.00	0.00

Lastfall 2

Randbedingung 1 Knicken in y/z-Richtung möglich
 Knicklastfaktoren $n_y / n_z = 112.75 / 11.43$ -
 Schlankheiten $\lambda_y / \lambda_z = 24.18 / 75.95$ -

Ausmitte inf.Kriechen wird vom Programm ermittelt.

Ungew. Ausmitte affin zur Knickfigur aufgebracht.
 Knicklängenfaktoren $\beta_y / \beta_z = 0.45 / 0.98$ -

LF 2

Ungewollte Ausmitte

Ky	H	ey	Kz	H	ez
	[m]	[cm]		[m]	[cm]
--	1.63	1.00	--	2.86	2.19

Lastfall 2 Regelbemessung nach linearer Th.I.O. mit 1.00-facher Last

 LF 2 Th.I.O.
 Schnittgrößen

K	N	My	Mz	Qy	Qz
	[kN]	[kNm]	[kNm]	[kN]	[kN]
1	100.00	-10.00	0.00	0.00	-9.21
2	109.60	-19.00	0.00	0.00	3.59
3	529.60	-27.87	0.00	0.00	3.59
3	538.79	0.00	0.00	0.00	12.34

 Biegemoment
 M 1:90

um y-Achse

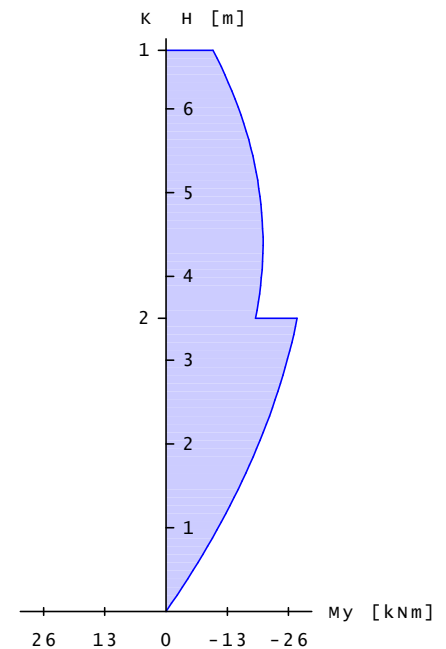
 LF 2 Th.I.O.
 Verformungen

K	wy	wz	dy	dz
	[cm]	[cm]	[rad]	[rad]
1	0.00	0.00	-0.00286	0.00000
2	0.00	0.60	-0.00074	0.00000
3	0.00	0.00	0.00311	0.00000

Verformung
M 1:90

in z-Richtung

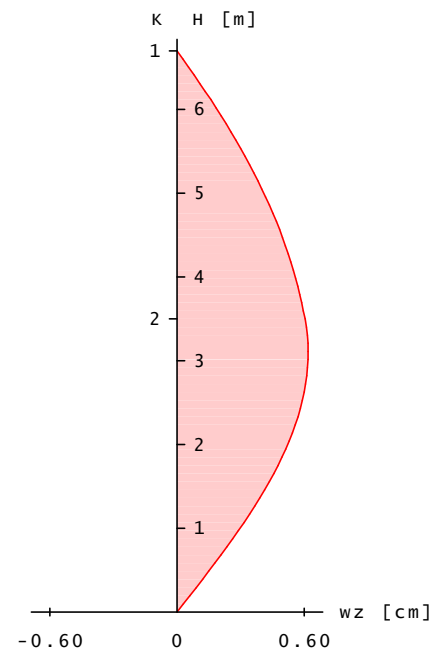

LF 2 Th.I.O.
Bruchschnittgrößen

K	Nu [kN]	Myu [kNm]	Mzu [kNm]	EpsS [%.]	EpsB [%.]	my [%]
1	822.80	-82.28	0.00	0.99	-3.50	0.40
2	444.49	-77.06	0.00	2.36	-3.50	0.40
	1163.41	-61.22	0.00	0.31	-3.50	0.74
3	2164.19	0.00	0.00	-2.00	-2.00	0.74

Lastfall 2 Knicksicherheitsnachweis n. Th.II.O. mit 1.75-facher Last

LF 2 KSNW
Schnittgrößen

K	N [kN]	My [kNm]	Mz [kNm]	Qy [kN]	Qz [kN]
1	175.00	-17.50	0.00	1.18	-37.56
2	191.80	-94.18	1.73	-0.67	-8.08
	926.80	-109.70	1.73	-6.41	-14.64
3	942.88	0.00	0.00	9.10	60.38

Biegemomente
M 1:90

um z-Achse

um y-Achse

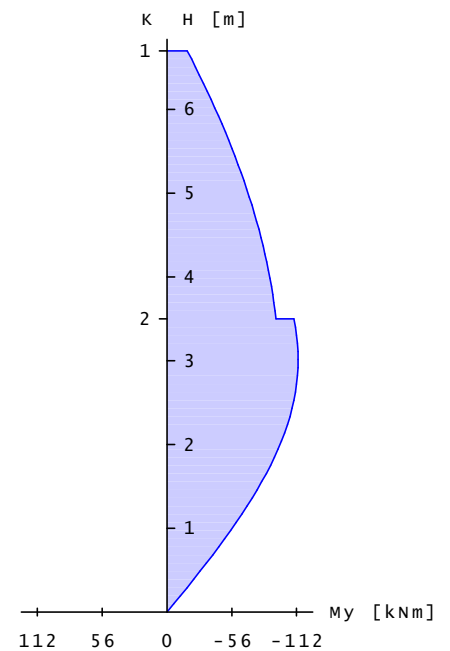
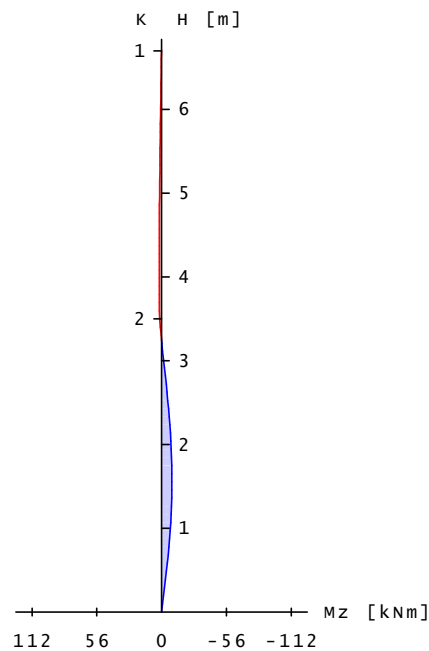

LF 2 KSNW
Verformungen

K	wy u [cm]	wz u [cm]	wy k [cm]	wz k [cm]	wy [cm]	wz [cm]
1	0.00	0.00	0.00	0.00	0.00	0.00
2	0.00	2.08	0.00	0.46	0.00	11.24
3	0.00	0.00	0.00	0.00	0.00	0.00

Vorverformungen
M 1:90

in y-Richtung

in z-Richtung

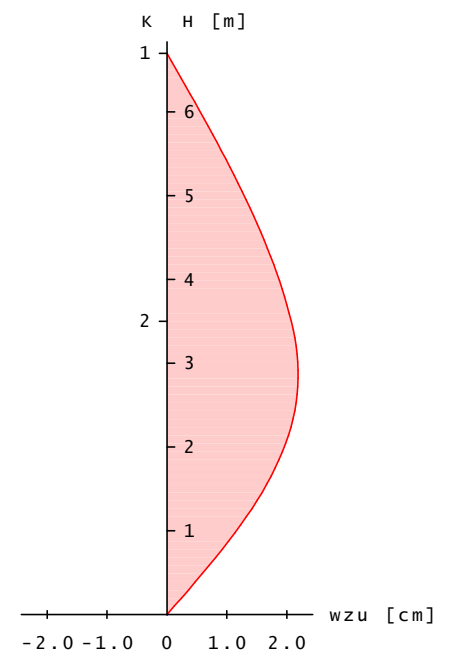
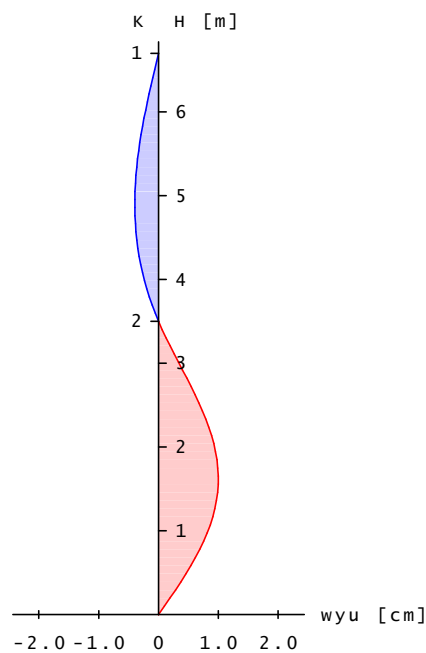

LF 2 KSNW
 Bruchschnittgrößen

K	Nu [kN]	Myu [kNm]	Mzu [kNm]	EpsS [%]	EpsB [%]	my [%]
1	963.24	-96.32	0.00	0.78	-3.50	1.01
2	191.80	-94.18	1.73	3.05	-3.50	1.01
3	3113.22	0.00	0.00	-1.99	-2.01	2.90

 LF 2 KSNW
 Auflagergr. / 1.75

K	Hy [kN]	HZ [kN]	A [kN]	My [kNm]	Mz [kNm]
1	-0.32	16.44	0.00	0.00	0.00
2	0.61	0.00	0.00	0.00	0.00
3	-0.30	5.11	538.79	0.00	0.00

Lastfall 2 Schnittgrößenermittlung n. Th.II.O. für Gebrauchszustand

 LF 2 GZ
 Verformungen

K	wy u [cm]	wz u [cm]	wy k [cm]	wz k [cm]	wy [cm]	wz [cm]
1	0.00	0.00	0.00	0.00	0.00	0.00
2	0.00	2.08	0.00	0.46	0.00	4.85
3	0.00	0.00	0.00	0.00	0.00	0.00

 Verformungen
 M 1:90

in y-Richtung

in z-Richtung

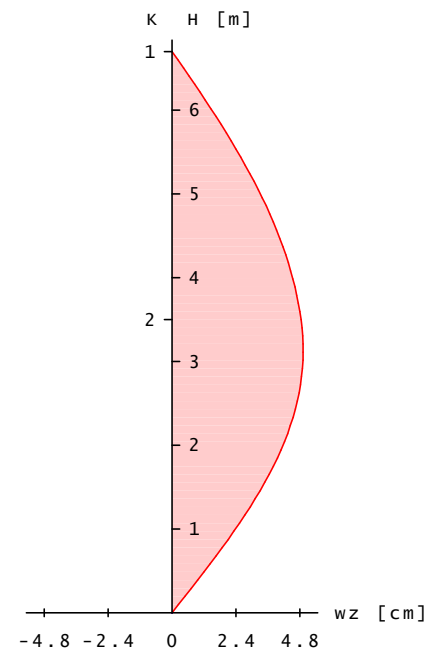
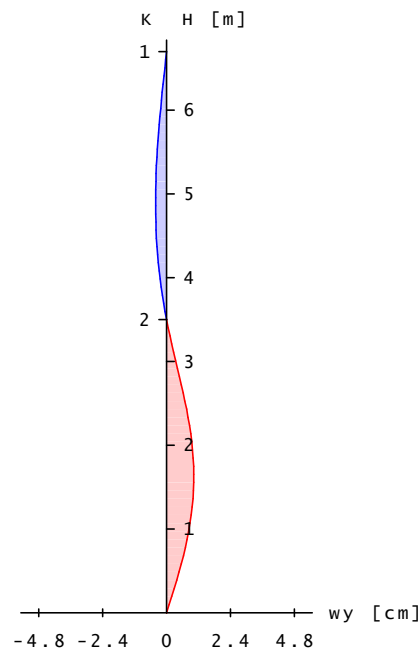
 LF 2 GZ
 Auflagergrößen

K	Hy [kN]	HZ [kN]	A [kN]	My [kNm]	Mz [kNm]
1	-0.25	12.35	0.00	0.00	0.00
2	0.48	0.00	0.00	0.00	0.00
3	-0.23	9.20	538.79	0.00	0.00

Lastfall 1 bis 2 Erforderliche Bewehrung (ohne Verankerungslängen)

von [m]	bis [m]	Q	Typ Bew.Art	BSt	ges.As [cm ²]	my [%]
6.70	3.50	1	Allgem. Form	500	12.07	1.01
3.50	0.00	2	Allgem. Form	500	30.43	2.90

Bewehrungslagen

Q	Lage	y1 [cm]	z1 [cm]	y2 [cm]	z2 [cm]	As [cm ²]
1	1	25.00	4.80			1.10
	2	36.00	12.00			1.10
	3	36.00	24.00			1.10
	4	46.00	24.00			1.10
	5	46.00	31.00			1.10
	6	36.00	31.00			1.10
	7	14.00	31.00			1.10
	8	4.00	31.00			1.10
	9	4.00	24.00			1.10
	10	14.00	24.00			1.10
	11	14.00	12.00			1.10
2	1	25.00	14.00			2.77
	2	36.00	14.00			2.77
	3	36.00	24.00			2.77
	4	46.00	24.00			2.77
	5	46.00	31.00			2.77
	6	36.00	31.00			2.77
	7	14.00	31.00			2.77
	8	4.00	31.00			2.77
	9	4.00	24.00			2.77
	10	14.00	24.00			2.77
	11	14.00	14.00			2.77

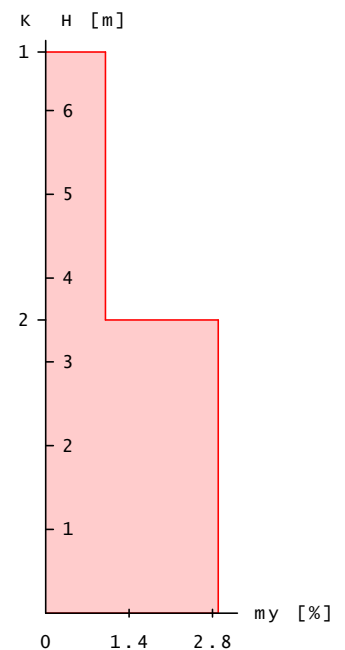
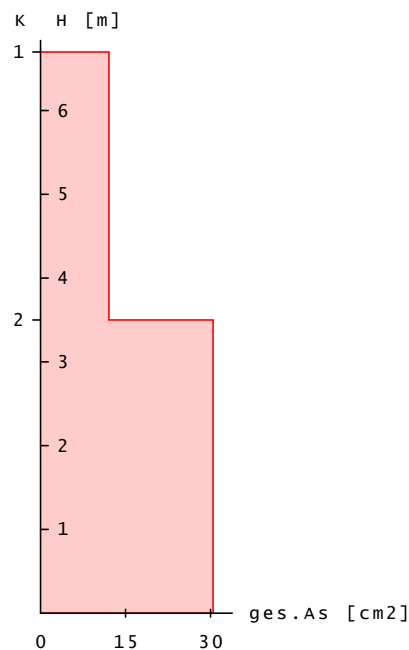
**Bewehrung
M 1:90**

Bewehrungswahl

von [m]	bis [m]	Q	Typ	Bew.-Lage	n	ds [mm]
6.70	3.50	1	Polygon	1	1	14
				2	1	14
				3	1	14
				4	1	14
				5	1	14
				6	1	14

von [m]	bis [m]	Q	Typ	Bew.-Lage	n	ds [mm]
				7	1	14
				8	1	14
				9	1	14
				10	1	14
				11	1	14
3.50	0.00	2	Polygon	1	1	20
				2	1	20
				3	1	20
				4	1	20
				5	1	20
				6	1	20
				7	1	20
				8	1	20
				9	1	20
				10	1	20
				11	1	20

Vorhandene
Bewehrung

von [m]	bis [m]	Q	Typ	n	ges.As [cm ²]	my [%]
6.70	3.50	1	Polygon	11	16.93	1.41
3.50	0.00	2	Polygon	11	34.56	3.29

Pos. B406a Allgemeines Stützensystem

In Querrichtung wird die Stütze zur Stabilisierung der angekoppelten Innenstützen herangezogen. Die Stütze erhält die gesamte Windlast einer Hallenseite. Die Bewehrung wird konstant über die gesamte Stützenlänge durchgeführt. Es wird angenommen, daß die Stütze in beiden Richtungen nicht gegen Knicken seitlich gehalten sein kann. Um die Werte 50 cm unterhalb des Binderauflagers ansehen zu können, wird dort ein zusätzlicher Knoten eingefügt.

System	A	vK	bK	von [m]	bis [m]	h [m]	Versatz [cm]	y/z [cm]	Q
	1	1	2	7.80	6.20	1.60	0.0	0.0	1
	2	2	3	6.20	5.70	0.50	11.5	0.0	2
	3	3	4	5.70	0.00	5.70	0.0	0.0	2

Fundamentfedern	vLF	bLF	Cr	by [m]	bz [m]	Bodenart/E [MN/m ²]
	0	1	Crz	1.50	1.50	Sand, scharf, dicht

Angehängte Pendelstützen	vLF	bLF	K	P [kN]	l [m]	Anzahl	Richtung
	0	0	2	216.00	6.20	1	y-Achse
	1	1	2	250.00	6.20	1	y-Achse

Randbedingungen	RB	K	Verschiebung [kN/m]		Verdrehung [kNm/rad]	
			Cty	Ctz	Cry	Crz
	1	2	-35	frei	frei	frei
		4	starr	starr	starr	142193
	2	2	-40	frei	frei	frei
		4	starr	starr	starr	142193

C>0 Federkonstante aus elastischer Knotenlagerung
 C<0 Federkonstante aus angehängten Pendelstützen
 Für KSNW mit Faktor GammaL berücksichtigt

Querschnitte	Q	Typ	Bew.Art	b/D	d/Di	b1	d1
				[cm]	[cm]	[cm]	[cm]
	1	R	AsI=Asr	17.00	35.00	4.80	4.80
	2	R	Eckstäbe	40.00	35.00	4.80	4.80

Materialien	Q	B	BSt	Feuchte			Zement		Konsistenz		t0 [Tage]
				my-	my+	mydin	phi	A	gamma		
				[%]	[%]	[%]	[-]	[cm ²]	[kN/m ³]		
	1-2			70%			Z35F, Z45F	KP:plastisch		10	
	1	35	500	0.40	9.00	0.80	2.54	595		25.00	
	2	35	500	0.40	9.00	0.80	2.45	1400		25.00	

M 1:10

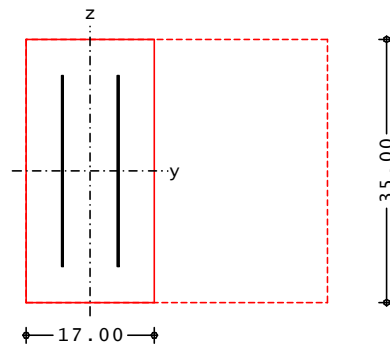

Abschnitt 1

M 1:10

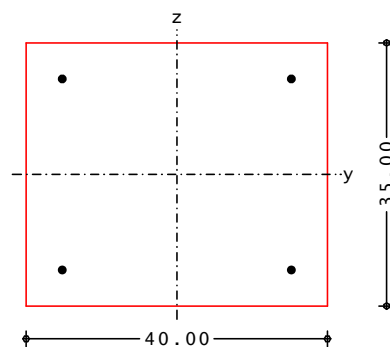

Abschnitt 2-3

Belastung

Knotenlasten und Abschnittslasten für LF 0 bis 1

Zusammenst. V1

 Ständige Last entspricht
 Kriecherzeugende Dauerlast = 404.00 kN

Zusammenst. V2

Schnee = 68.00 kN

Zusammenst. qy1

 winddruck $c_p * q$ $0.8 * 0.5 = 0.40$ kN/m

LF 0	K	2 vertik. $e_y/z = 10.0/$	0.0 cm	V =	404.0	kN
LF 1	K	2 vertik. $e_y/z = 10.0/$	0.0 cm	V =	404.0	kN
	K	2 vertik. $e_y/z = 1.0/$	0.0 cm	V =	68.0	kN
	A	1- 3 Gleichl. Y		qy=	0.40	kN/m

Die Eigenlast der Stütze wird berücksichtigt.

Lastfall 0
M 1:110

System in y-Richtung

in z-Richtung

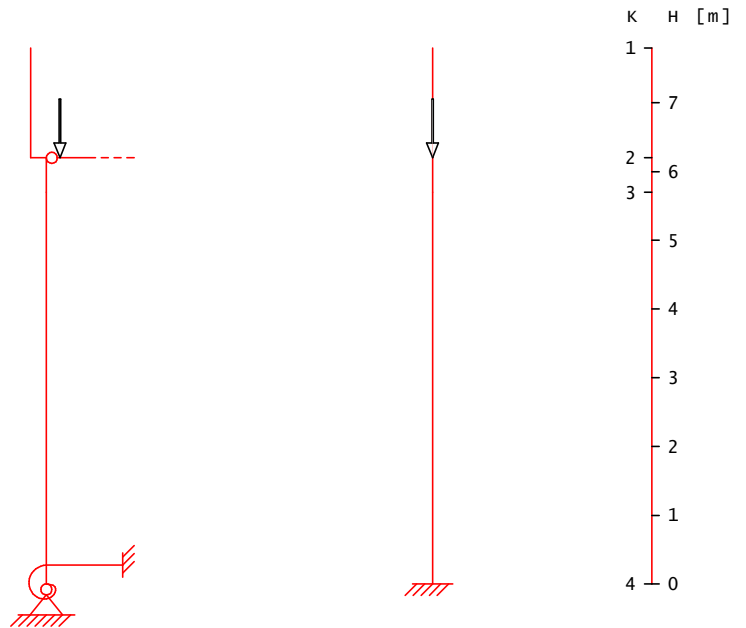

Lastfall 1
M 1:110

System in y-Richtung

in z-Richtung

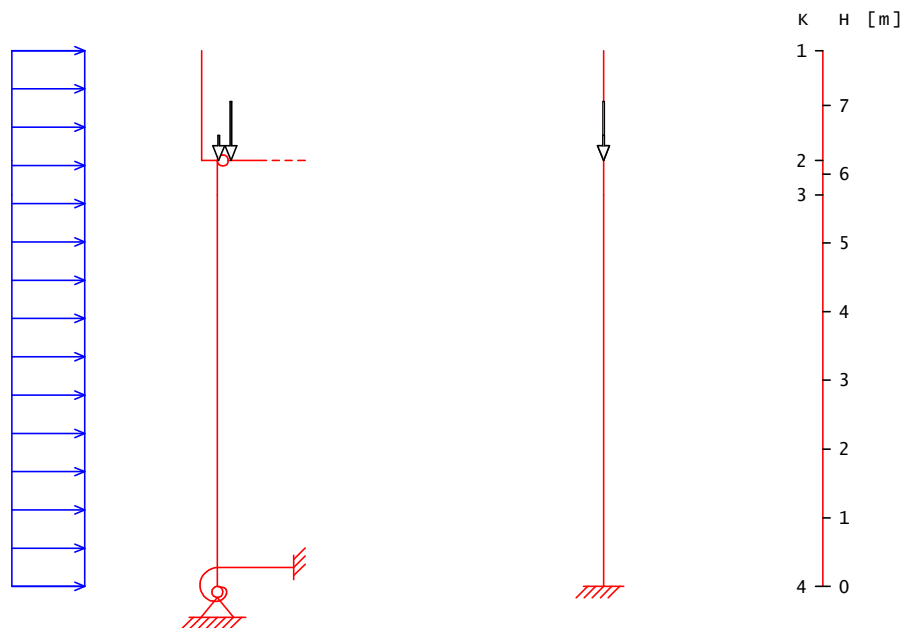

Bemessung

Lastfall 0 Berechnung für Dauerlast nach linear-elastischer Th.II.O. mit einem wirksamen Elastizitätsmodul $E_b / (1 + \phi)$

Randbedingung 1 Knicken in y/z-Richtung möglich
 Knicklastfaktoren $n_y / n_z = 3.68 / 4.21 -$

LF 0 Biegesteifigkeiten	Q	my [%]	(EI _y) _b [MNm ²]	(EI _z) _b [MNm ²]	EI _y [MNm ²]	EI _z [MNm ²]
	1	0.40	5.8	1.4	6.1	1.4
	2	2.80	14.1	18.4	27.3	37.4

Ungew. Ausmitte affin zur Knickfigur aufgebracht.
 Knicklängenfaktoren $\beta_y / \beta_z = 1.96 / 1.57 -$

LF 0 Ungewollte Ausmitte	H [m]	ey [cm]	H [m]	ez [cm]
	7.80	5.10	7.80	4.08

LF 0 Verformungen	K	wy [cm]	wz [cm]	dy [rad]	dz [rad]
	1	10.93	5.34	0.00962	0.02014
	2	7.71	3.80	0.00961	0.02009
	3	6.72	3.32	0.00954	0.01946
	4	0.00	0.00	0.00000	0.00117

Verformungen
 M 1:105

in y-Richtung

in z-Richtung

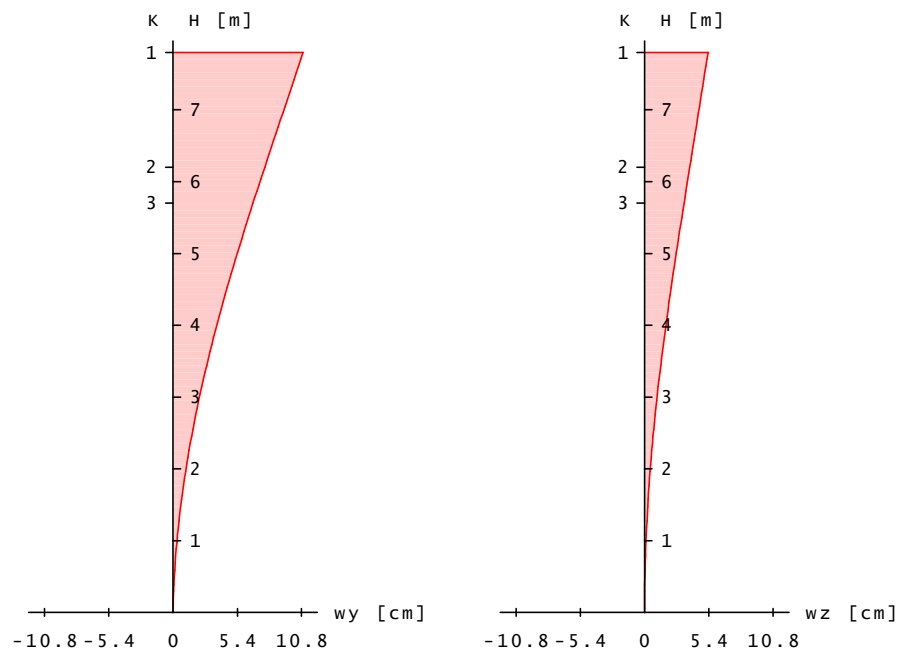

Lastfall 1

Randbedingung 2 Knicken in y/z-Richtung möglich
 Knicklastfaktoren $n_y / n_z = 5.06 / 6.43 -$
 Schlankheiten $\lambda_{y / z} = 136.80 / 121.35 -$

Ausmitte inf.Kriechen wird vom Programm ermittelt.

Ungew. Ausmitte affin zur Knickfigur aufgebracht.
 Knicklängenfaktoren $\beta_y / \beta_z = 2.03 / 1.57$ -

LF 1	Ky	H	ey	Kz	H	ez
Ungewollte Ausmitte		[m]	[cm]		[m]	[cm]
	--	7.80	5.27	--	7.80	4.09

Lastfall 1 Regelbemessung nach linearer Th.I.O. mit 1.00-facher Last

LF 1 Th.I.O.	K	N	My	Mz	Qy	Qz
Schnittgrößen		[kN]	[kNm]	[kNm]	[kN]	[kN]
	1	0.00	0.00	0.00	0.00	0.00
	2	2.38	0.00	0.51	0.64	0.00
	3	474.38	0.00	41.32	1.36	0.00
	4	476.13	0.00	42.05	1.56	0.00
		496.08	0.00	57.45	3.84	0.00

Biegemoment um z-Achse
 M 1:105

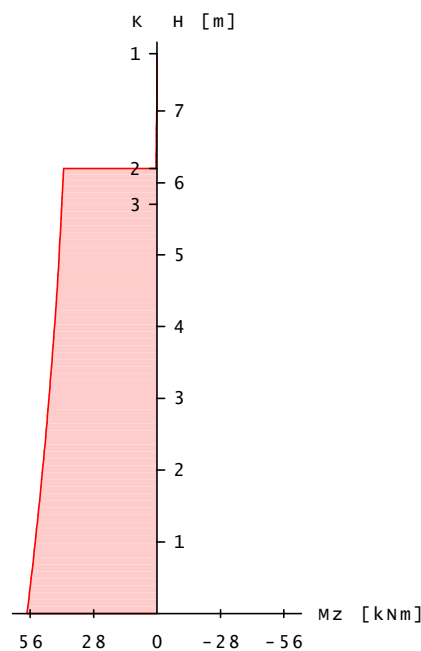

LF 1 Th.I.O.
 Verformungen

K	wy	wz	dy	dz
	[cm]	[cm]	[rad]	[rad]
1	2.61	0.00	0.00000	0.00516
2	1.79	0.00	0.00000	0.00510
3	1.54	0.00	0.00000	0.00477
4	0.00	0.00	0.00000	0.00040

Verformung
M 1:105

in y-Richtung

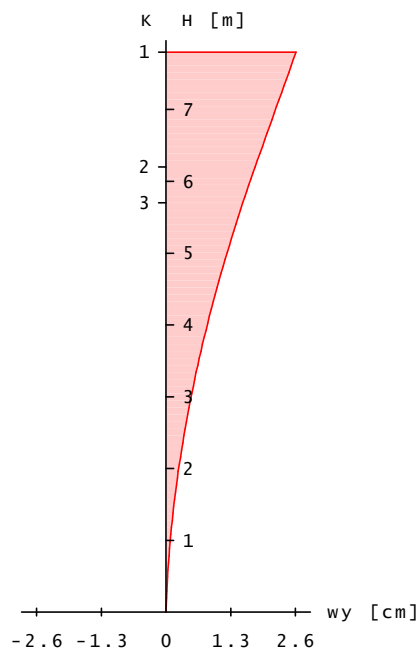

LF 1 Th.I.O.
Bruchschnittgrößen

K	Nu [kN]	Myu [kNm]	Mzu [kNm]	EpsS [%.]	EpsB [%.]	my [%]
1	1468.46	0.00	18.58	-2.00	-2.00	0.40
2	53.68	0.00	11.55	5.00	-1.59	0.40
	2029.64	0.00	176.78	0.67	-3.50	0.42
3	2012.73	0.00	177.75	0.70	-3.50	0.42
4	1662.42	0.00	192.51	1.49	-3.50	0.42

Lastfall 1 Knicksicherheitsnachweis n. Th.II.O. mit 1.75-facher Last

LF 1 KSNW
Schnittgrößen

K	N [kN]	My [kNm]	Mz [kNm]	Qy [kN]	Qz [kN]
1	0.00	0.00	0.00	0.00	0.00
2	4.17	0.07	1.12	1.39	0.09
	830.16	0.07	72.53	69.85	17.09
3	833.23	8.57	107.40	69.41	17.04
4	868.14	70.01	406.72	23.30	0.00

Biegemomente
M 1:105

um z-Achse

um y-Achse

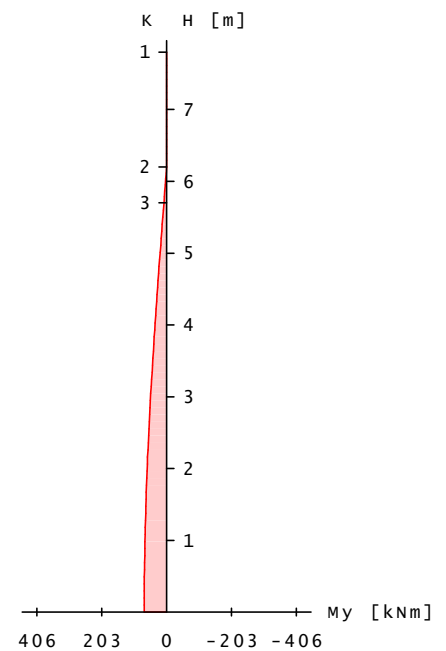
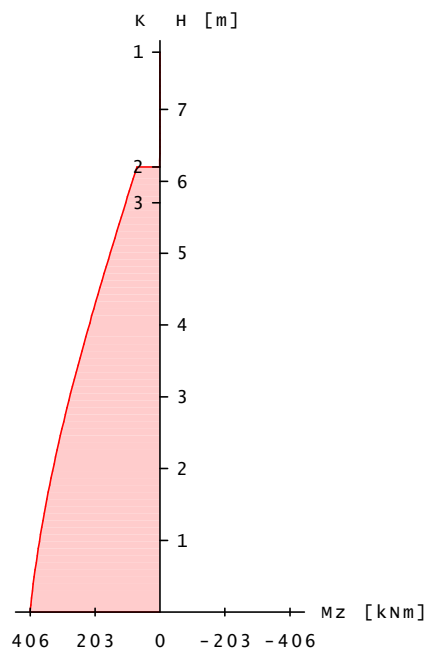

LF 1 KSNW
Verformungen

K	wy u [cm]	wz u [cm]	wy k [cm]	wz k [cm]	wy [cm]	wz [cm]
1	5.27	4.09	3.39	0.78	37.21	11.63
2	3.83	2.91	2.33	0.56	26.56	8.33
3	3.38	2.54	2.01	0.49	23.31	7.30
4	0.00	0.00	0.00	0.00	0.00	0.00

Vorverformungen
M 1:105

in y-Richtung

in z-Richtung

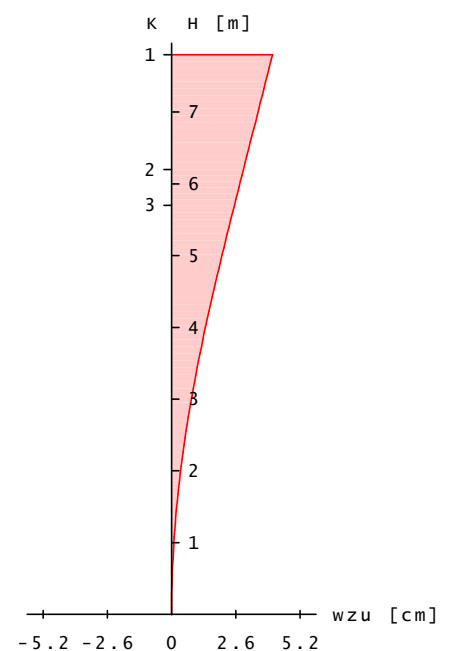
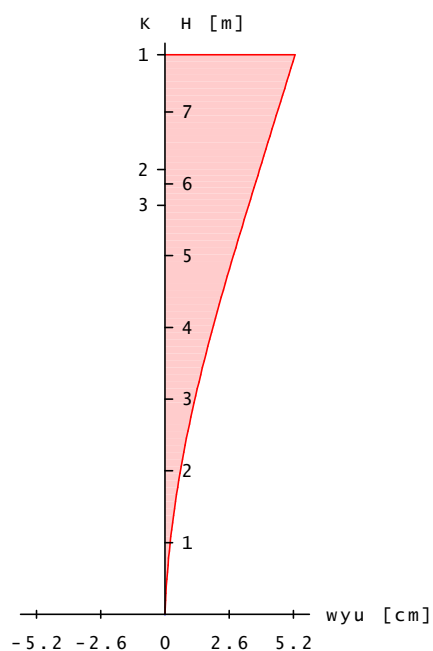

LF 1 KSNW
 Bruchschnittgrößen

K	Nu [kN]	Myu [kNm]	Mzu [kNm]	EpsS [%.]	EpsB [%.]	my [%]
1	1468.46	2.01	25.14	-2.00	-2.00	0.40
2	39.58	0.65	10.62	5.00	-1.55	0.40
3	3321.30	0.27	290.17	0.04	-3.50	3.05
4	2704.72	27.82	348.62	0.81	-3.50	3.05
4	868.14	70.01	406.72	3.32	-3.50	3.05

 LF 1 KSNW
 Auflagergr. / 1.75

K	Hy [kN]	HZ [kN]	A [kN]	My [kNm]	Mz [kNm]
2	-8.22	0.00	0.00	0.00	0.00
4	11.34	0.00	496.08	40.01	232.41

Lastfall 1 Schnittgrößenermittlung n. Th.II.O. für Gebrauchszustand

 LF 1 GZ
 Verformungen

K	wy u [cm]	wz u [cm]	wy k [cm]	wz k [cm]	wy [cm]	wz [cm]
1	5.27	4.09	3.39	0.78	15.52	6.44
2	3.83	2.91	2.33	0.56	10.97	4.59
3	3.38	2.54	2.01	0.49	9.60	4.01
4	0.00	0.00	0.00	0.00	0.00	0.00

 Verformungen
 M 1:105

in y-Richtung

in z-Richtung

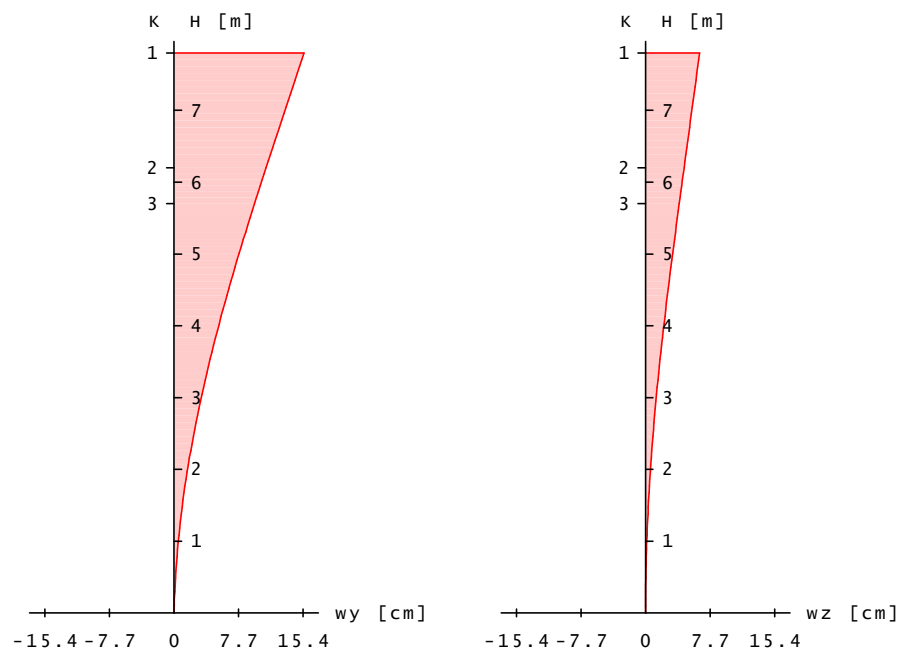
 LF 1 GZ
 Auflagergrößen

K	Hy [kN]	HZ [kN]	A [kN]	My [kNm]	Mz [kNm]
2	-1.94	0.00	0.00	0.00	0.00
4	5.06	0.00	496.08	22.18	118.02

Lastfall 1 bis 1 Erforderliche Bewehrung (ohne Verankerungslängen)

von [m]	bis [m]	Q	Typ	Bew.Art	BSt	ges.As [cm ²]	my [%]
7.80	6.20	1	R	Asl=Asr	500	2.38	0.40
6.20	0.00	2	R	Eckstäbe	500	42.75	3.05

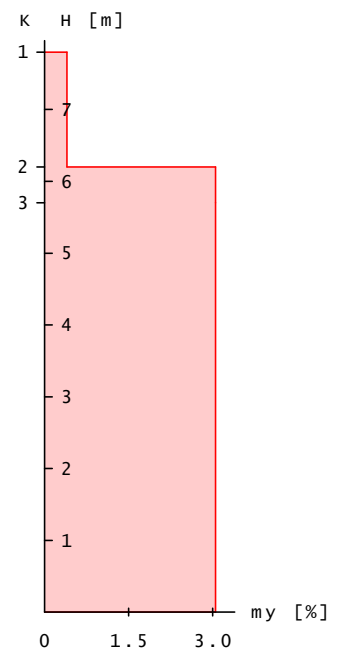
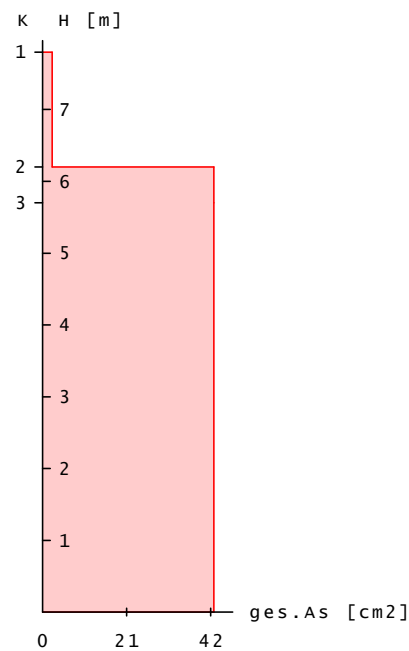
Bewehrung
M 1:105

Bewehrungswahl

von [m]	bis [m]	Q	Typ	Bew.-Lage	n	ds [mm]
7.80	6.20	1	Rechteck	je Ecke	1	14
6.20	0.00	2	Rechteck	je Ecke	3	25

Vorhandene Bewehrung

von [m]	bis [m]	Q	Typ	n	ges.As [cm²]	my [%]
7.80	6.20	1	Rechteck	4	6.16	1.03
6.20	0.00	2	Rechteck	12	58.90	4.21

Pos. B406b
Allgemeines Stützensystem
System

A	vK	bK	von [m]	bis [m]	h [m]	Versatz [cm]	y/z [cm]	Q
1	1	2	9.60	8.10	1.50	0.0	0.0	1
2	2	3	8.10	4.40	3.70	0.0	0.0	1
3	3	4	4.40	0.00	4.40	0.0	0.0	1

Randbedingungen

RB	K	Verschiebung [kN/m]	verdrehung [kNm/rad]		
		Cty	Ctz	Cry	Crz
1	3	starr	frei	frei	frei
	4	starr	starr	30000	30000

C>0 Federkonstante aus elastischer Knotenlagerung

Querschnitte

Q	Typ	Bew.Art	b/D [cm]	d/Di [cm]	b1 [cm]	d1 [cm]
1	R	Eckstäbe	30.00	40.00	3.50	3.50

Materialien

Q	B	BSt	my- [%]	my+ [%]	mydin [%]	phi [-]	A [cm ²]	gamma [kN/m ³]
1	45	500	0.40	9.00	0.80	2.50	1200	25.00

M 1:10

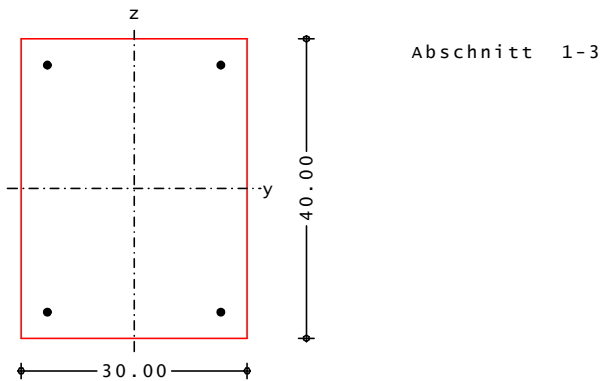
Belastung

Knotenlasten und Abschnittslasten für LF 0 bis 2

LF 0	K 1	vertik.	ey/z = 0.0/-27.5 cm	V = 3.8 kN
	K 1	vertik.	ey/z = 0.0/ 27.5 cm	V = 8.9 kN
	K 1	vertik.	ey/z = 22.5/ 0.0 cm	V = 12.9 kN
	K 3	vertik.	ey/z = 0.0/-27.5 cm	V = 45.7 kN
	K 3	vertik.	ey/z = 0.0/ 27.5 cm	V = 84.6 kN
LF 1	K 1	vertik.	ey/z = 0.0/-27.5 cm	V = 3.8 kN
	K 1	vertik.	ey/z = 0.0/ 27.5 cm	V = 8.9 kN
	K 1	vertik.	ey/z = 22.5/ 0.0 cm	V = 12.9 kN
	K 1	vertik.	ey/z = 22.5/ 0.0 cm	V = 22.9 kN
	K 1	Horizontal	Y	Hy= 10.0 kN
	K 1	Horizontal	Z	HZ= 5.9 kN
	K 3	vertik.	ey/z = 0.0/-27.5 cm	V = 59.5 kN
	K 3	vertik.	ey/z = 0.0/ 27.5 cm	V = 110.2 kN
LF 2	A 1-	1 Gleichl.	Y	qy= 1.79 kN/m
	A 2-	3 Gleichl.	Y	qy= 1.12 kN/m
	K 1	vertik.	ey/z = 0.0/-27.5 cm	V = 3.8 kN
	K 1	vertik.	ey/z = 0.0/ 27.5 cm	V = 8.9 kN

K 1	Vertik.	$e_{y/z} = 22.5/ 0.0$	cm	V =	12.9	kN
K 1	Vertik.	$e_{y/z} = 22.5/ 0.0$	cm	V =	22.9	kN
K 1	Horizontal	Y		Hy=	10.0	kN
K 1	Horizontal	Z		HZ=	5.9	kN
K 3	Vertik.	$e_{y/z} = 0.0/-27.5$	cm	V =	59.5	kN
K 3	Vertik.	$e_{y/z} = 0.0/ 27.5$	cm	V =	110.2	kN

Die Eigenlast der Stütze wird berücksichtigt.

Lastfall 0
M 1:135

System in y-Richtung

in z-Richtung

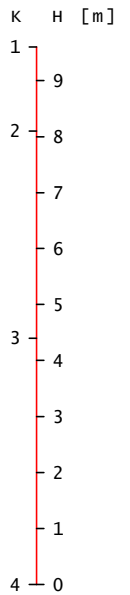
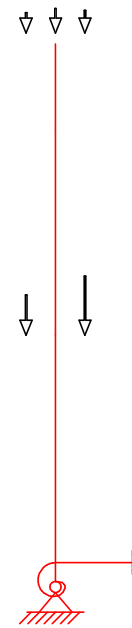
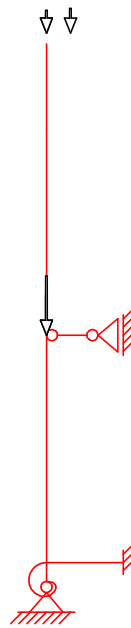

Lastfall 1
M 1:135

System in y-Richtung

in z-Richtung

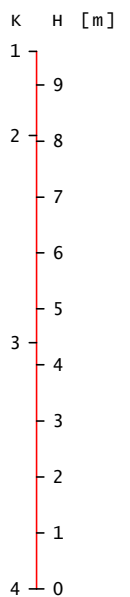
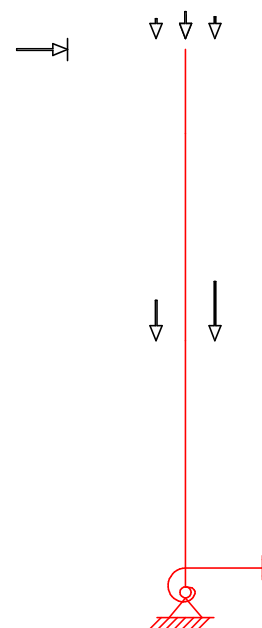
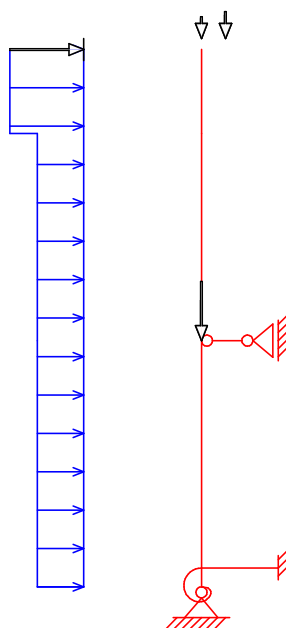

Lastfall 2
 M 1:135

System in y-Richtung

in z-Richtung

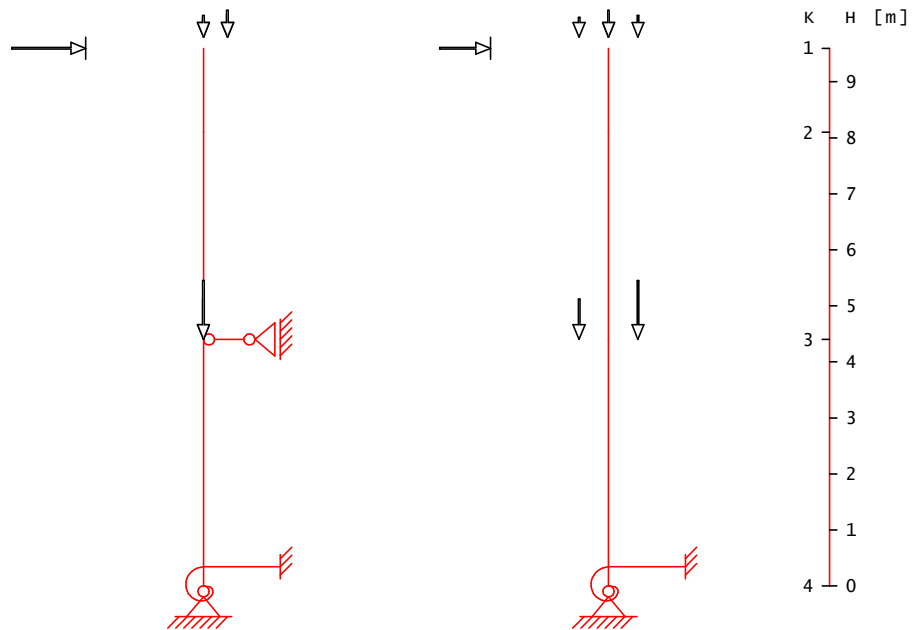

Bemessung

 Lastfall 0 Berechnung für Dauerlast nach linear-elastischer Th.II.O. mit einem wirksamen Elastizitätsmodul $E_b / (1 + \phi)$

 Randbedingung 1 Knicken in y/z-Richtung möglich
 Knicklastfaktoren $n_y / n_z = 27.95 / 10.42$ -

 LF 0
 Biegesteifigkeiten

Q	my [%]	(EI _y) _b [MNm ²]	(EI _z) _b [MNm ²]	EI _y [MNm ²]	EI _z [MNm ²]
1	2.15	16.9	9.5	31.6	16.7

 Ungew. Ausmitte affin zur Knickfigur aufgebracht.
 Knicklängenfaktoren $\beta_y / \beta_z = 0.59 / 1.33$ -

 LF 0
 Ungewollte Ausmitte

H [m]	e _y [cm]	H [m]	e _z [cm]
9.60	1.88	9.60	4.25

 LF 0
 Verformungen

K	w _y [cm]	w _z [cm]	d _y [rad]	d _z [rad]
1	2.31	6.56	0.00872	0.00592
2	1.45	5.26	0.00859	0.00541
3	0.00	2.23	0.00760	0.00196
4	0.00	0.00	0.00181	-0.00039

Verformungen
M 1:130

in y-Richtung

in z-Richtung

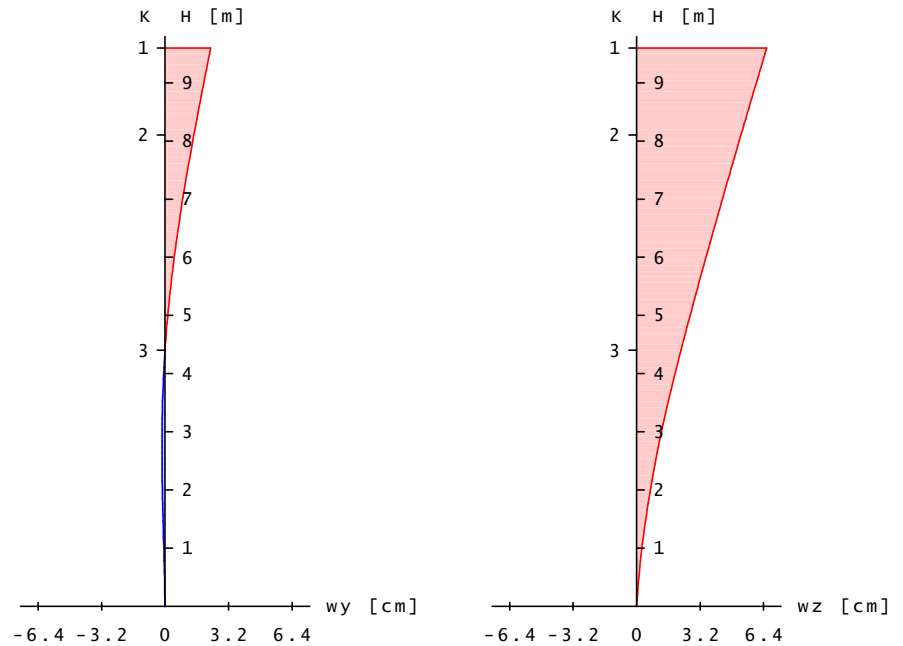

Lastfall 1

Randbedingung 1 Knicken in y/z-Richtung möglich
 Knicklastfaktoren $n_y / n_z = 32.63 / 10.58$ -
 Schlankheiten $\lambda_y / \lambda_z = 73.74 / 129.48$ -

Ausmitte inf.Kriechen wird vom Programm ermittelt.

Ungew. Ausmitte affin zur Knickfigur aufgebracht.
 Knicklängenfaktoren $\beta_y / \beta_z = 0.67 / 1.56$ -

LF 1

Ungewollte Ausmitte

Ky	H [m]	ey [cm]	Kz	H [m]	ez [cm]
--	9.60	2.13	--	9.60	4.98

Lastfall 1 Regelbemessung nach linearer Th.I.O. mit 1.00-facher Last

LF 1 Th.I.O.
Schnittgrößen

K	N [kN]	My [kNm]	Mz [kNm]	Qy [kN]	Qz [kN]
1	48.50	1.40	8.05	10.00	5.90
2	53.00	10.25	25.07	12.68	5.90
3	64.10	32.08	79.67	16.83	5.90
	233.80	46.02	79.67	-25.37	5.90
4	247.00	71.98	-21.13	-20.45	5.90

Biegemomente
M 1:130

um z-Achse

um y-Achse

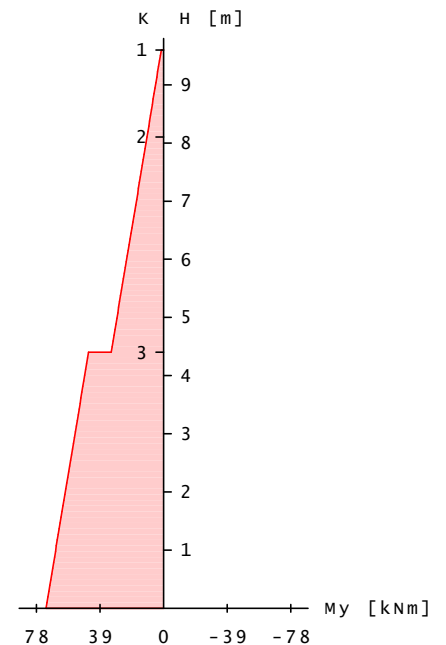
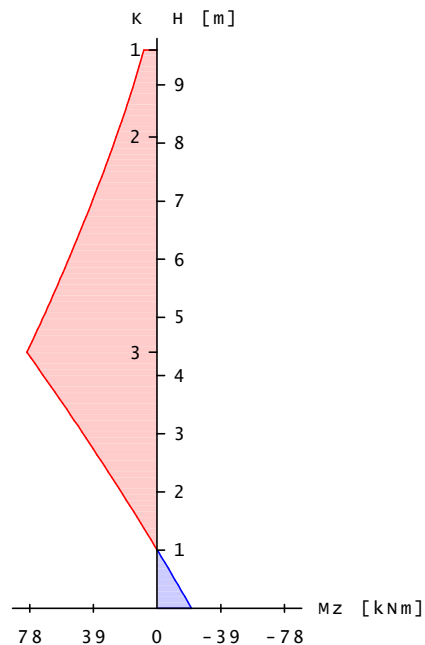

LF 1 Th.I.O.
Verformungen

K	wy [cm]	wz [cm]	dy [rad]	dz [rad]
1	3.67	6.12	0.00826	0.00933
2	2.32	4.89	0.00811	0.00860
3	0.00	2.09	0.00679	0.00292
4	0.00	0.00	0.00240	-0.00070

Verformungen
M 1:130

in y-Richtung

in z-Richtung

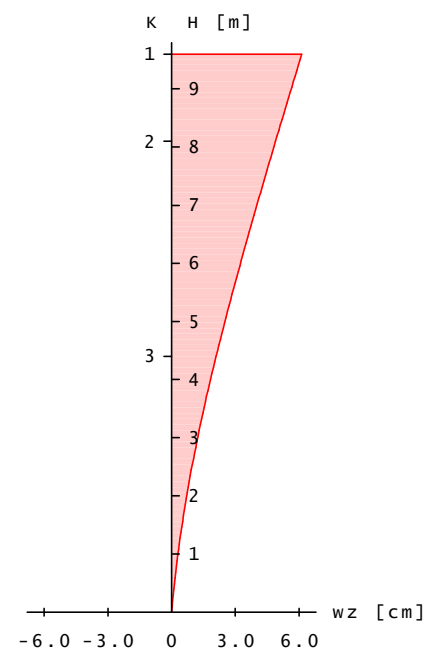
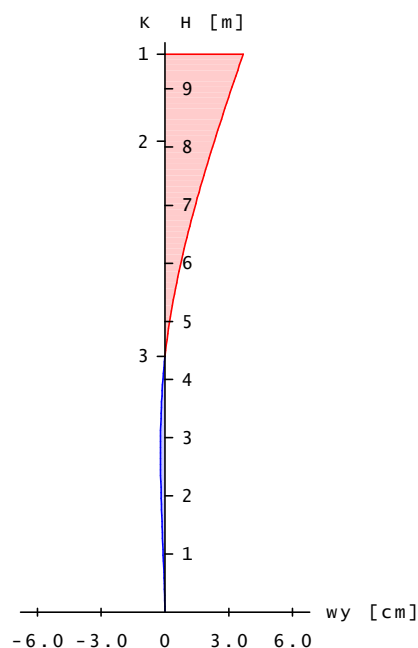

LF 1 Th.I.O.
Bruchschnittgrößen

K	Nu [kN]	Myu [kNm]	Mzu [kNm]	EpsS [%.]	EpsB [%.]	my [%]
1	616.72	17.83	102.43	5.00	-2.79	0.46
2	97.07	18.78	45.91	5.00	-1.54	0.46
3	343.63	66.47	162.54	5.00	-3.05	1.81
4	112.17	56.14	139.42	5.00	-2.51	1.81
	409.15	80.54	139.42	5.00	-3.33	1.42
	739.06	215.39	-63.23	4.01	-3.50	1.42

Lastfall 1 Knicksicherheitsnachweis n. Th.II.O. mit 1.75-facher Last
**LF 1 KSNW
Schnittgrößen**

K	N [kN]	My [kNm]	Mz [kNm]	Qy [kN]	Qz [kN]
1	84.88	2.45	14.10	23.00	14.86
2	92.75	24.92	51.96	27.24	15.11
3	112.18	81.17	162.31	31.50	15.13
4	409.15	105.57	162.31	-47.88	27.86
	432.25	201.49	-62.50	-47.88	14.18

**Biegemomente
M 1:130**

um z-Achse

um y-Achse

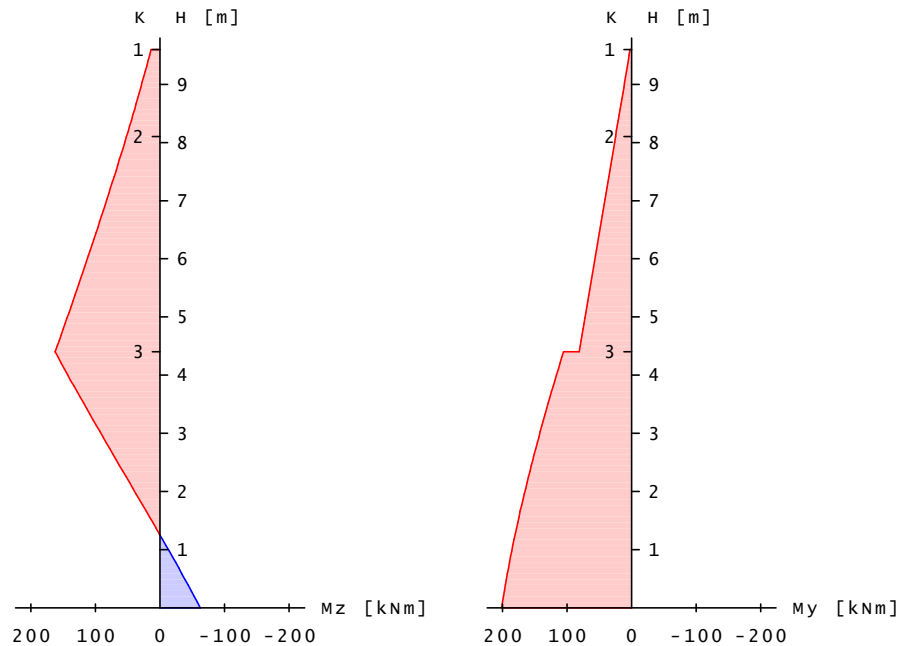

**LF 1 KSNW
Verformungen**

K	wy u [cm]	wz u [cm]	wy k [cm]	wz k [cm]	wy [cm]	wz [cm]
1	2.13	4.98	0.25	1.06	23.82	37.87
2	1.36	4.03	0.14	0.83	14.68	29.96
3	0.00	1.82	0.00	0.31	0.00	12.17
4	0.00	0.00	0.00	0.00	0.00	0.00

Vorverformungen
M 1:130

in y-Richtung

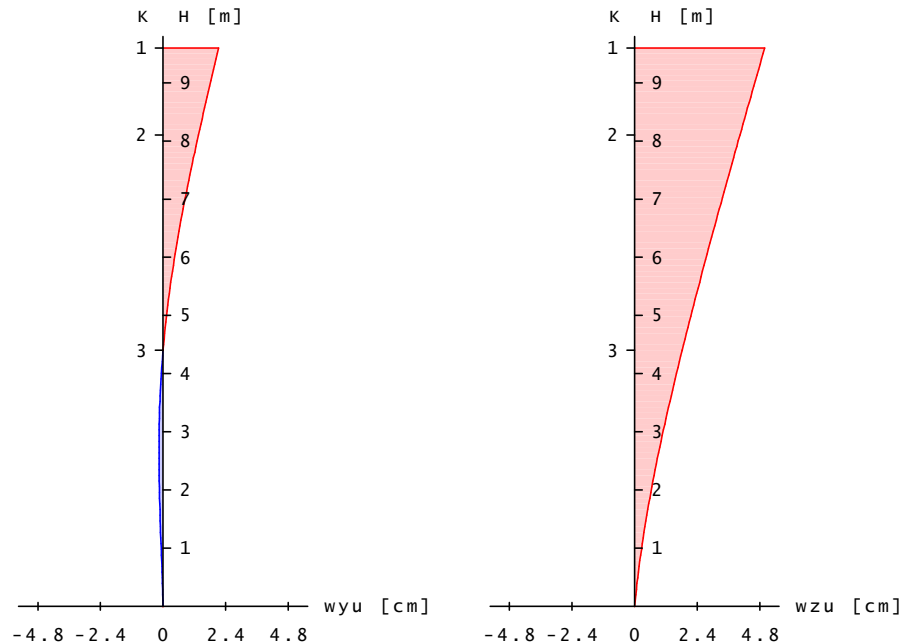
in z-Richtung



LF 1 KSNW
Bruchschnittgrößen

K	Nu [kN]	Myu [kNm]	Mzu [kNm]	EpsS [%.]	EpsB [%.]	my [%]
1	700.49	20.26	116.34	5.00	-3.09	0.55
2	92.75	24.92	51.96	5.00	-1.70	0.55
3	327.89	88.10	183.70	5.00	-3.28	2.18
4	112.17	81.17	162.31	5.00	-2.84	2.18
	409.15	105.57	162.31	4.81	-3.50	1.89
	508.03	236.81	-73.45	4.55	-3.50	1.89

LF 1 KSNW
Auflagergr. / 1.75

K	Hy [kN]	HZ [kN]	A [kN]	My [kNm]	Mz [kNm]
3	48.46	0.00	0.00	0.00	0.00
4	-26.70	5.90	247.00	115.14	-35.71

Lastfall 1 Schnittgrößenermittlung n. Th.II.O. für Gebrauchszustand
Ausgabe abgeschaltet. - Berechnung erfolgt intern.

Lastfall 2 Randbedingung 1 Knicken in y/z-Richtung möglich
Knicklastfaktoren $n_y / n_z = 32.63 / 10.58$ -
Schlankheiten $\lambda_y / \lambda_z = 73.74 / 129.48$ -

Ausmitte inf.Kriechen wird vom Programm ermittelt.

Ungew. Ausmitte affin zur Knickfigur aufgebracht.
Knicklängenfaktoren $\beta_y / \beta_z = 0.67 / 1.56$ -

LF 2
Ungewollte Ausmitte

Ky	H [m]	ey [cm]	Kz	H [m]	ez [cm]
--	9.60	2.13	--	9.60	4.98

Lastfall 2 Regelbemessung nach linearer Th.I.O. mit 1.00-facher Last

**LF 2 Th.I.O.
Schnittgrößen**

K	N [kN]	My [kNm]	Mz [kNm]	Qy [kN]	Qz [kN]
1	48.50	1.40	8.05	10.00	5.90
2	53.00	10.25	23.05	10.00	5.90
3	64.10	32.08	60.05	10.00	5.90
4	233.80	46.02	60.06	-17.53	5.90
	247.00	71.98	-17.09	-17.53	5.90

**Biegemomente
M 1:130**

um z-Achse

um y-Achse

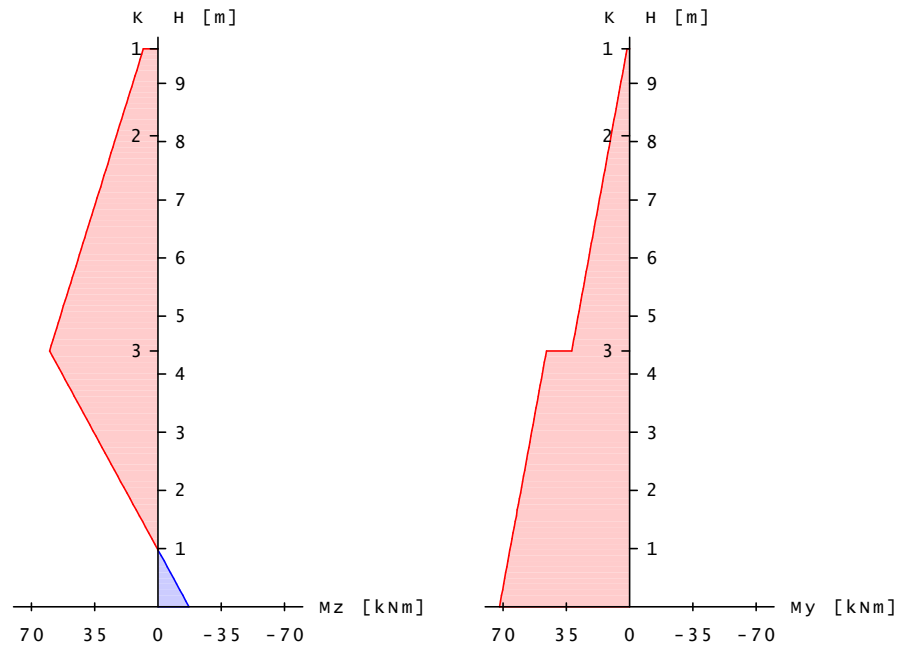

**LF 2 Th.I.O.
Verformungen**

K	wy [cm]	wz [cm]	dy [rad]	dz [rad]
1	2.91	6.12	0.00826	0.00759
2	1.82	4.89	0.00811	0.00689
3	0.00	2.09	0.00679	0.00227
4	0.00	0.00	0.00240	-0.00057

Verformungen
M 1:130

in y-Richtung

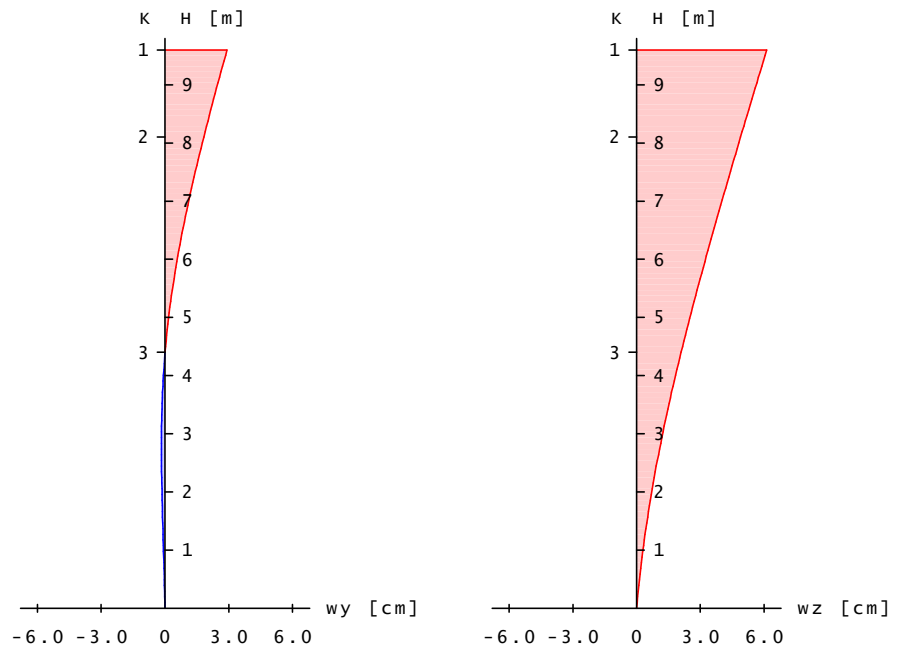
in z-Richtung



LF 2 Th.I.O.
Bruchschnittgrößen

K	Nu [kN]	Myu [kNm]	Mzu [kNm]	EpsS [%.]	EpsB [%.]	my [%]
1	575.77	16.65	95.62	5.00	-2.64	0.41
2	98.29	19.01	42.76	5.00	-1.54	0.41
3	284.79	55.09	123.88	5.00	-2.75	1.32
4	112.17	56.14	105.10	5.00	-2.43	1.32
5	409.15	80.54	105.10	5.00	-3.28	0.97
6	617.69	180.02	-42.74	5.00	-3.47	0.97

Lastfall 2 Knicksicherheitsnachweis n. Th.II.O. mit 1.75-facher Last

LF 2 KSNW
Schnittgrößen

K	N [kN]	My [kNm]	Mz [kNm]	Qy [kN]	Qz [kN]
1	84.88	2.45	14.10	22.90	15.66
2	92.75	26.16	48.26	22.42	15.97
3	112.18	85.58	127.04	19.35	15.96
4	409.15	109.98	127.04	-34.09	30.87
5	432.25	213.99	-52.92	-41.86	14.36

Biegemomente
M 1:130

um z-Achse

um y-Achse

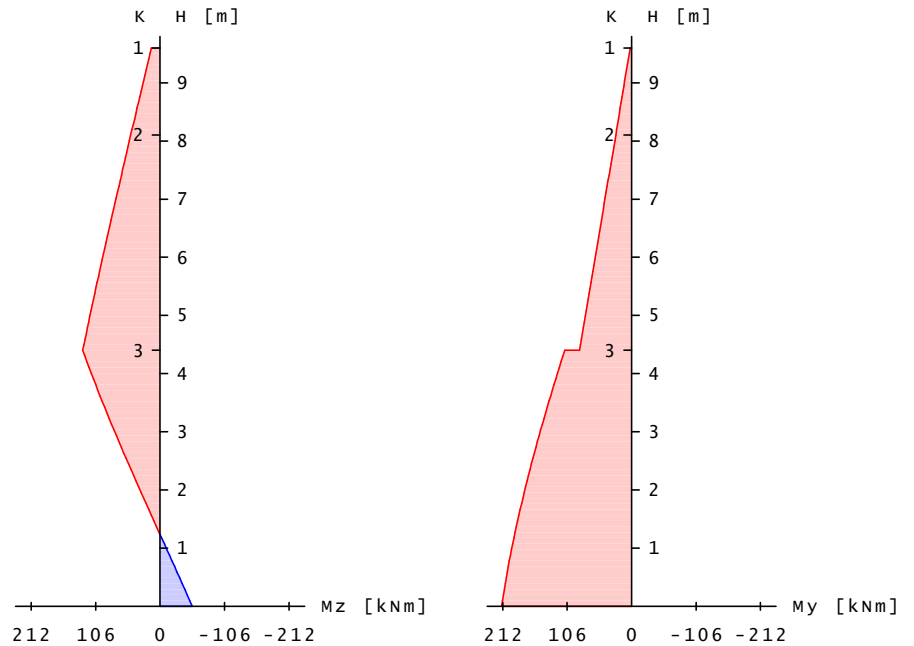

LF 2 KSNW
Verformungen

K	wy u [cm]	wz u [cm]	wy k [cm]	wz k [cm]	wy [cm]	wz [cm]
1	2.13	4.98	0.25	1.06	22.91	44.42
2	1.36	4.03	0.14	0.83	13.97	35.09
3	0.00	1.82	0.00	0.31	0.00	14.14
4	0.00	0.00	0.00	0.00	0.00	0.00

Vorverformungen
M 1:130

in y-Richtung

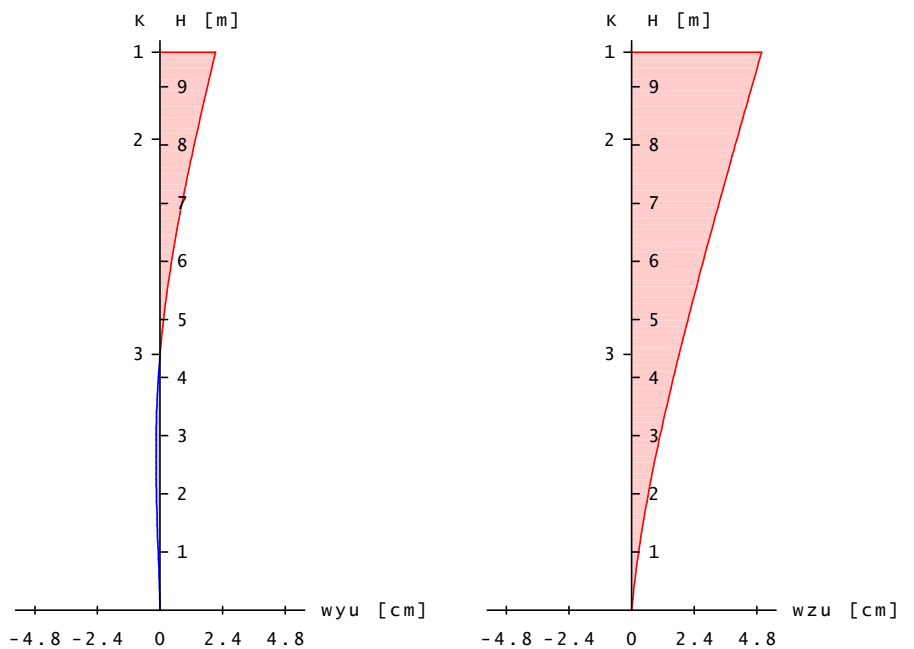
in z-Richtung



LF 2 KSNW
 Bruchschnittgrößen

K	Nu [kN]	Myu [kNm]	Mzu [kNm]	EpsS [%]	EpsB [%]	my [%]
1	658.98	19.06	109.45	5.00	-2.94	0.50
2	92.75	26.16	48.26	5.00	-1.72	0.50
3	280.18	79.03	145.80	5.00	-3.07	1.69
4	112.17	85.58	127.04	5.00	-2.84	1.69
4	428.69	115.23	133.11	4.79	-3.50	1.58
4	432.25	213.99	-52.92	5.00	-3.20	1.58

 LF 2 KSNW
 Auflagergr. / 1.75

K	Hy [kN]	HZ [kN]	A [kN]	My [kNm]	MZ [kNm]
3	33.34	0.00	0.00	0.00	0.00
4	-23.34	5.90	247.00	122.28	-30.24

 LF 2 KSNW
 Gleichgewicht

 Summe Ky = -2.84e-14 kN
 Summe Kz = -2.66e-14 kN
 Summe My = 1.23 kNm
 Summe Mz = 5.37e-1 kNm

 Lastfall 2 Schnittgrößenermittlung n. Th.II.O. für Gebrauchszustand
 Ausgabe abgeschaltet. - Berechnung erfolgt intern.

Lastfall 1 bis 2 Erforderliche Bewehrung (ohne Verankerungslängen)

von [m]	bis [m]	Q	Typ	Bew.Art	BSt	ges.As [cm ²]	my [%]
9.60	8.10	1	R	Eckstäbe	500	6.65	0.55
8.10	4.40	1	R	Eckstäbe	500	26.16	2.18
4.40	0.00	1	R	Eckstäbe	500	22.69	1.89

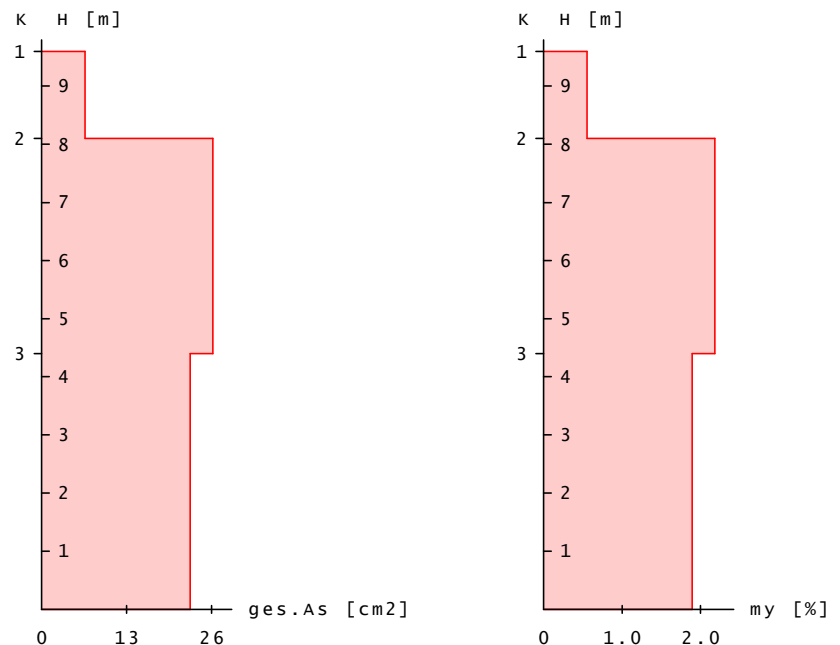
 Bewehrung
 M 1:130

Bewehrungswahl

von [m]	bis [m]	Q	Typ	Bew.-Lage	n	ds [mm]
9.60	8.10	1	Rechteck	je Ecke	1	16
8.10	4.40	1	Rechteck	je Ecke	3	20
4.40	0.00	1	Rechteck	je Ecke	3	16

Vorhandene
Bewehrung

von [m]	bis [m]	Q	Typ	n	ges. As [cm ²]	my [%]
9.60	8.10	1	Rechteck	4	8.04	0.67
8.10	4.40	1	Rechteck	12	37.70	3.14
4.40	0.00	1	Rechteck	12	24.13	2.01